

COLLECTION SYSTEMS ARE CUSTOM DESIGNED TO FIT EXISTING EQUIPMENT PLEASE INQUIRE OR VISIT CAMPBELLSYSTEMSINC.COM FOR MORE INFORMATION

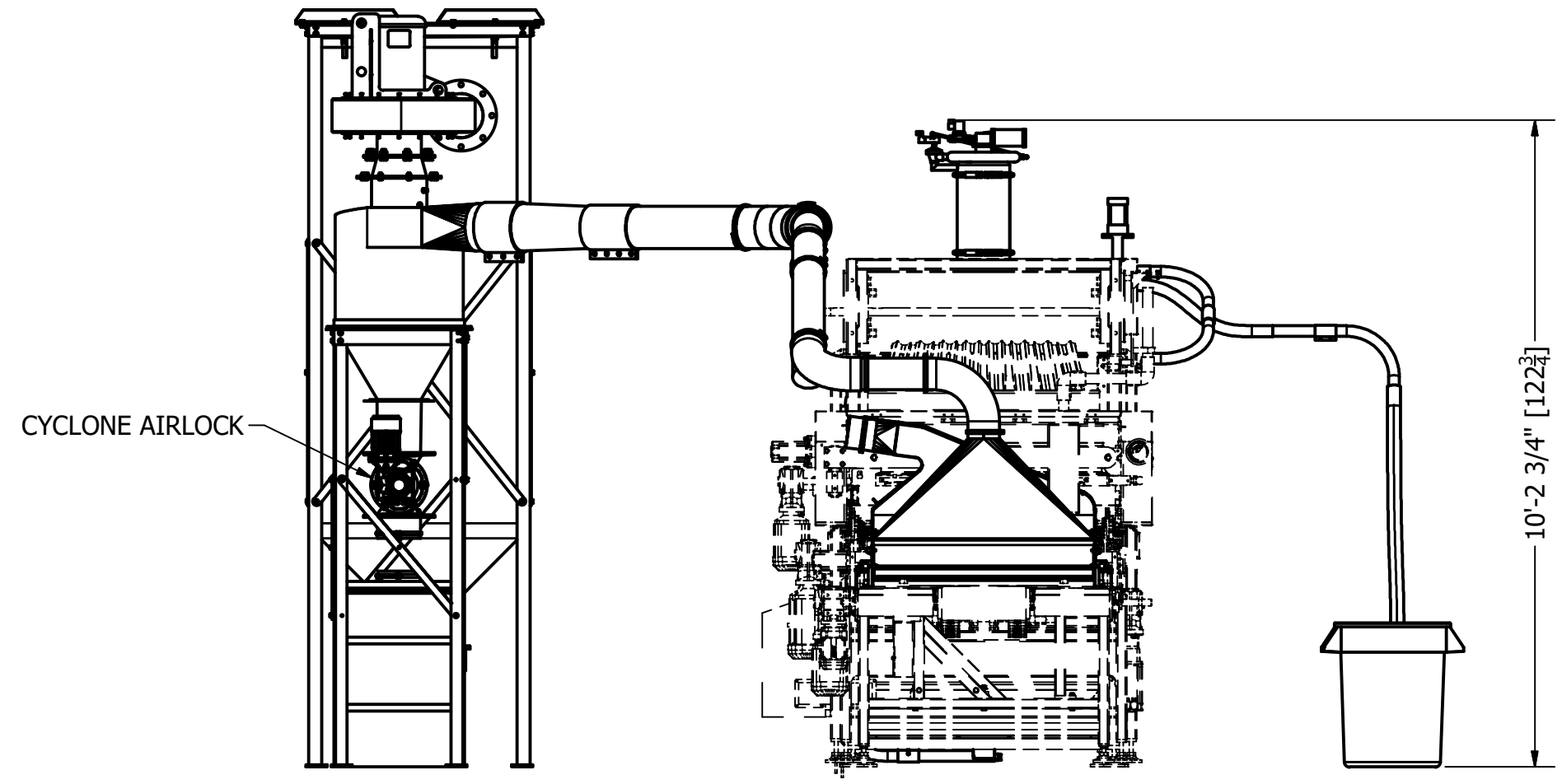
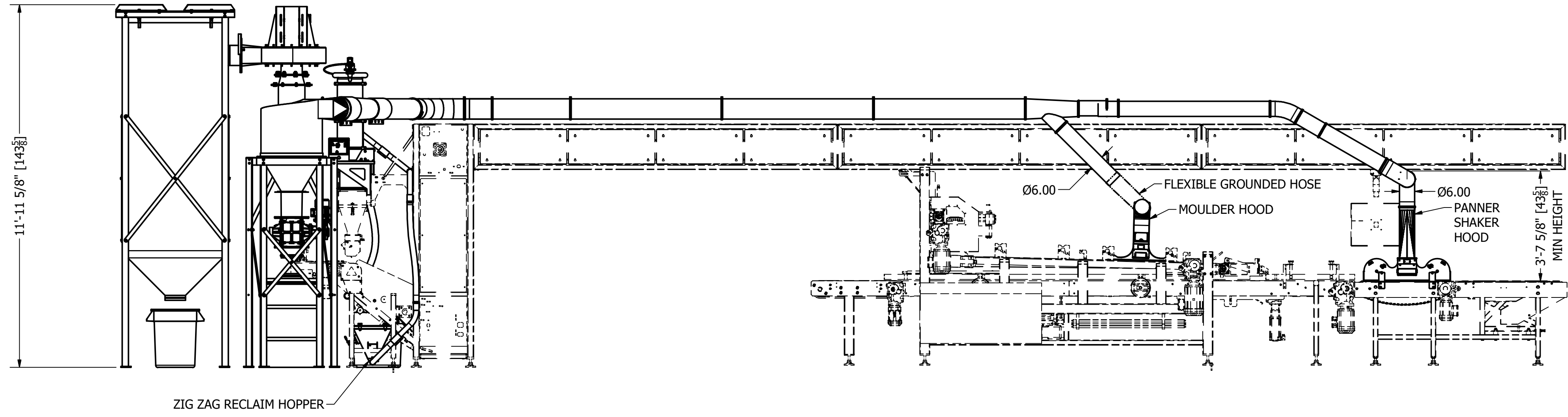
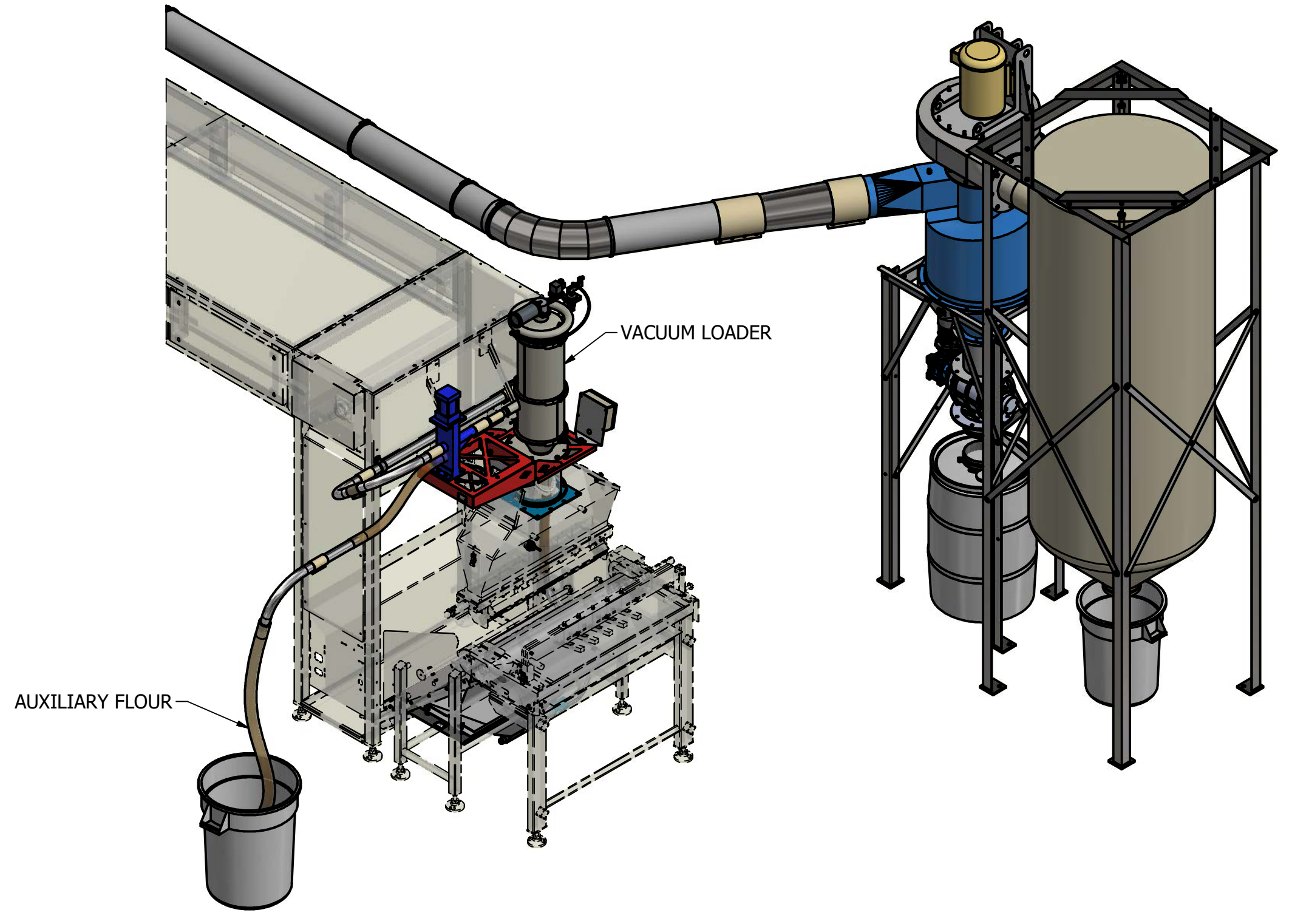
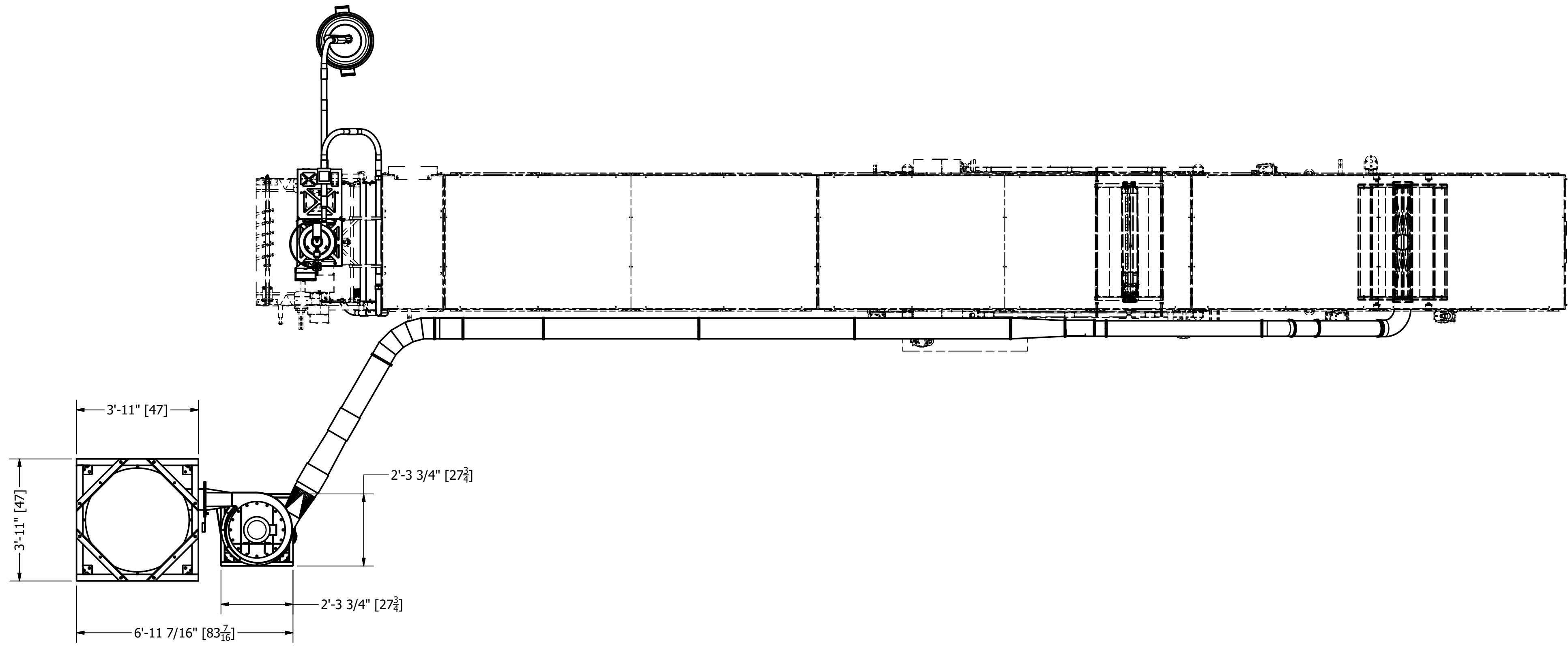

- UTILITIES:
- CONVEYOR HOOD RECLAIM SYSTEM:  
 BLOWER: 7.5HP 480 VAC / 60HZ 3 PHASE / 1500 CFM  
 AIRLOCK: 1/2 HP 480VAC / 60HZ 3 PHASE  
 CYCLONIC FILTRATION WITH EXHAUST FILTRATION BAG, BARREL ATTACHMENT  
 MOULDER HOOD: 24VDC SOLENOID / 20 CFM TO AIRBAR  
 PANNER HOOD: 24VDC SOLENOID / 40 CFM TO AIRBAR
  - INTERMITTENT RECLAIM SYSTEM:  
 VACUUM LOADER VENTURI: 24VDC / 31 SCFM @ 87PSI / 80-100 PSI / 1/2" NPT  
 VACUUM LOADER PULSE JET: 24VDC / 4 CFM / 3/8" NPT  
 DIVERTER VALVE PNEUMATICS: 24VDC / 80-100 PSI (OPTIONAL FOR AUXILIARY REFILL)  
 FLOUR HOPPER VIBRATOR: 24VDC / 5.5 SCFM / 80 PSI

DRAWING IS FOR REFERENCE ONLY  
 DIMENSIONS SUBJECT TO CHANGE FROM TIME OF PRINT AT MFR DISCRETION  
 AN APPROVAL DRAWING WILL BE SUBMITTED TO  
 INSURE PROPER FIT FOR YOUR APPLICATION

DRAWN David Hoffman	1/7/2019	CAMPBELL SYSTEMS INCORPORATED Bakery Dust Collection & Reclaim Equipment 770-641-5075	
CHECKED			
MFG		TITLE	
APPROVED GLENN CAMPBELL	1/7/2019	INTERMITTENT & CONTINUOUS FLOUR RECLAIM 8X BUN LINE	
SIZE D		DWG NO. IFR CFR 8X	REV
SCALE NTS		SHEET 1 OF 1	