

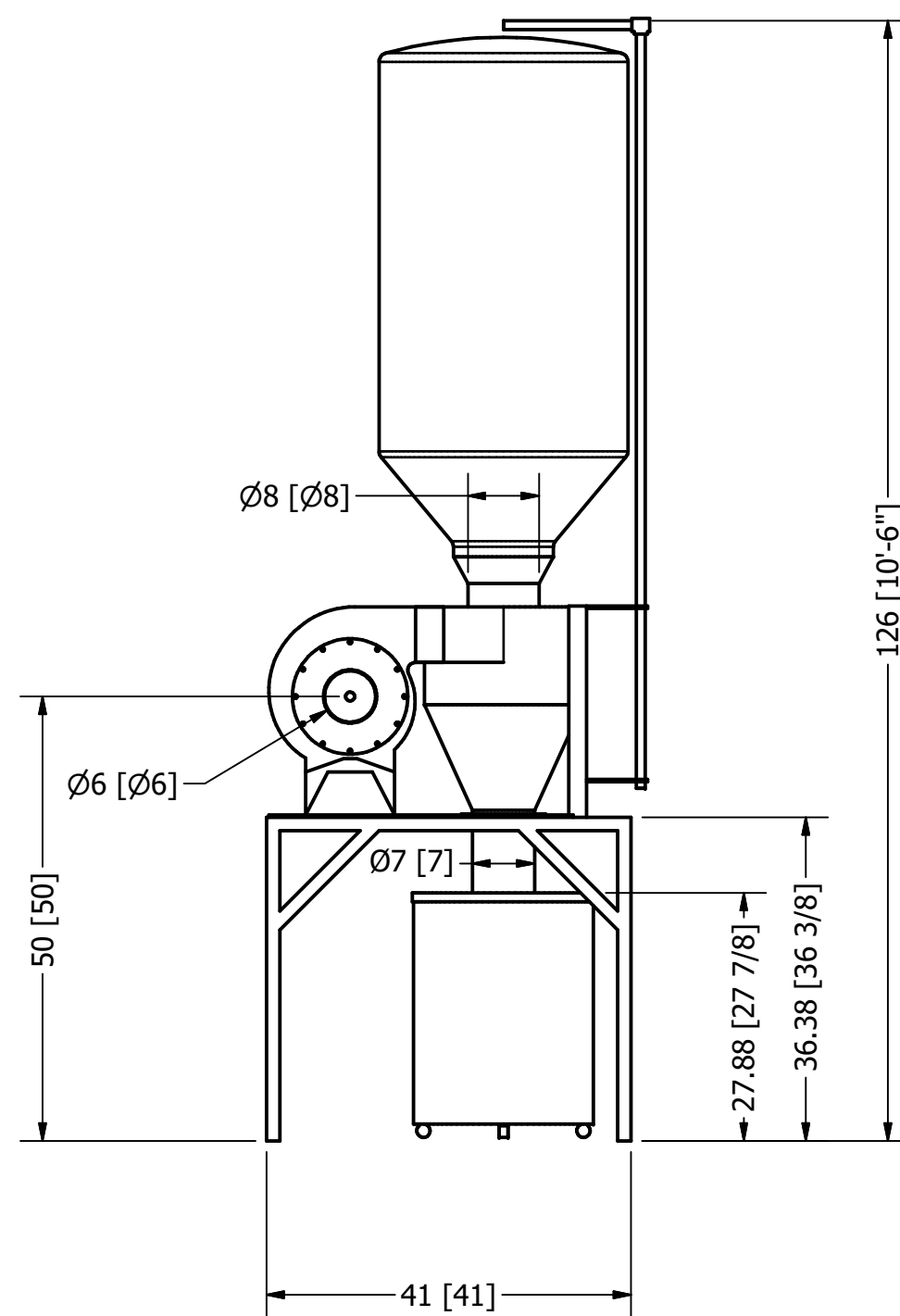

NOTES:

1. CONSTRUCTION: CARBON STEEL
HCF8-70048 BRIGHT SILVER POWDER COAT
2. APPROX SHIPPING WEIGHT: 430 LBS
3. OPTIONAL INLET SIZES: Ø6", Ø5" OR Ø4"
4. DUST STORAGE CAPACITY: 4.7 FT³
5. FILTER SPECS: AREA: 38 FT²
MATERIAL: 12OZ SINGED POLYESTER FELT
6. ENSURE THAT DUCT AND EQUIPMENT IS PROPERLY GROUNDED
7. UTILITY: 1-1/2 HP, 230/460 VAC 6/3 AMPS

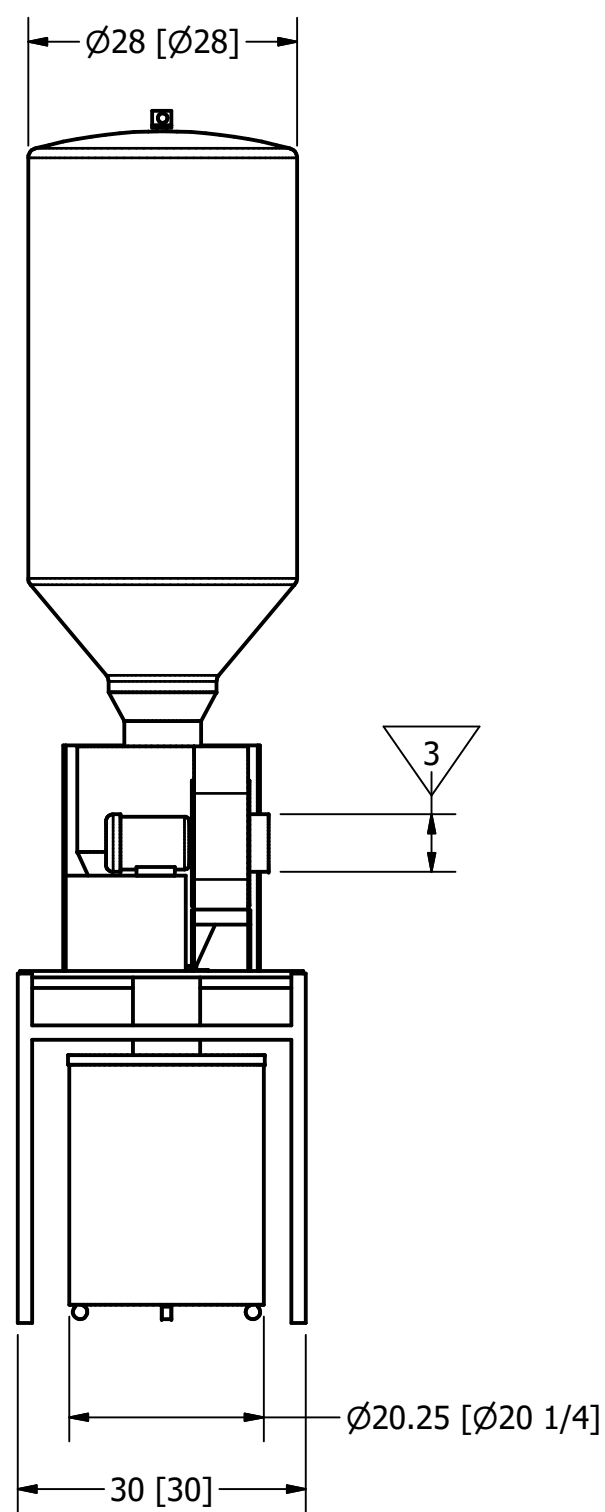
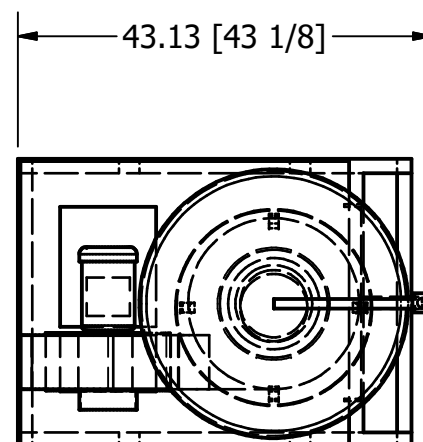
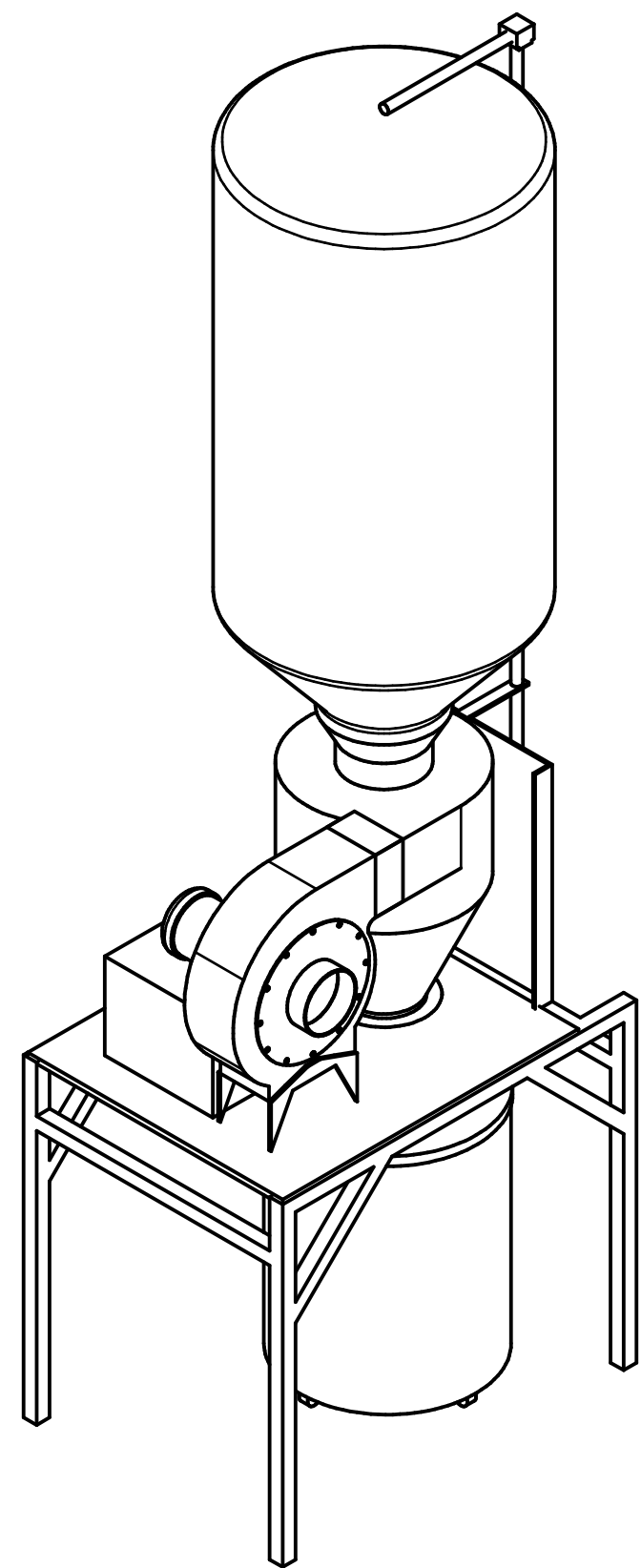

DRAWN David Hoffman	3/2/2018	 CAMPBELL SYSTEMS INCORPORATED Bakery Dust Collection & Reclaim Equipment 770-641-5075
CHECKED		
QA		TITLE
MFG		CFR800 PAN CLEANER
APPROVED		SIZE
		C
		DWG NO
		10015-1317
		REV
		0
		SCALE
		1 / 20
		SHEET 1 OF 1